

# PRODUCT SPECIFICATION

*Part Number*  
**PDC39SM-CADW01**

## Details

- 0.39" (10.00mm) SMD LED Display
- 1 Digit, 7 Segment
- Common Anode or Common Cathode
- Emitting Color: White
- InGaN chip technology

## Features

- Low power consumption
- RoHS Compliant
- Gray Face, White Segments or Black Face, White Segments
- Easy mounting on PCB or socket

## Mechanical Dimensions

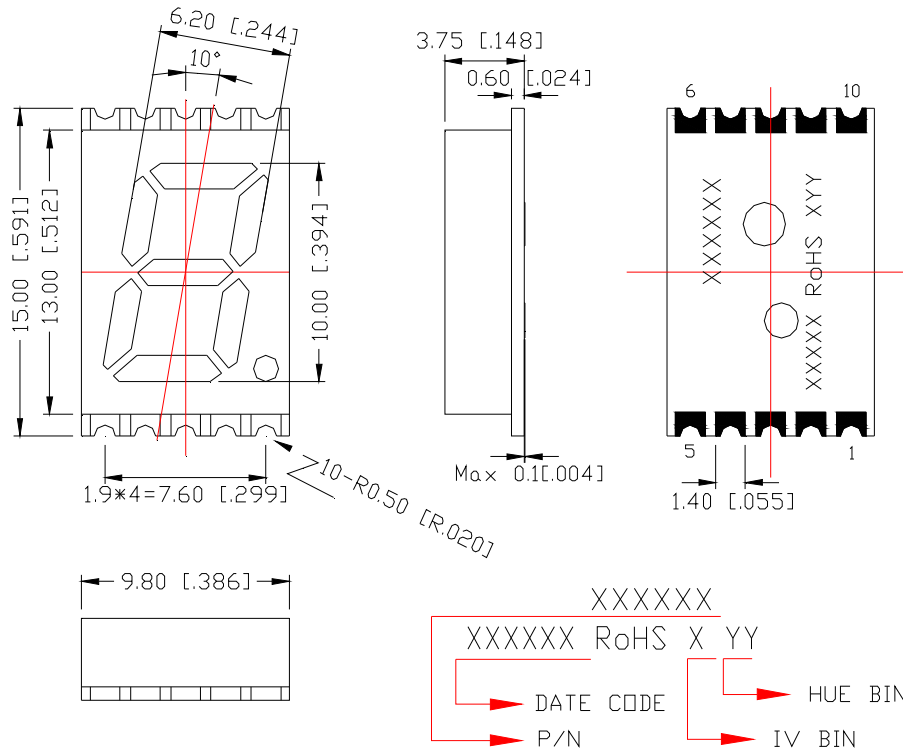

## Notes:

1. Dimension in millimeter [inch], tolerance is  $\pm 0.25$  [0.010] and angle is  $\pm 1^\circ$  unless otherwise noted
2. Specifications subject to change without notice





**Device Selection Guide**

Model Number		Chip		Note
Common Anode	Common Cathode	Material	Emitting Color	Add “-BW” to end of part number for Black Face, White Segment version
PDC39SM-CADW01	PDC39SM-CCDW01	InGaN	Blue	

**Absolute Maximum Ratings at Ta=25 °C**

Parameter	Symbol	Rating	Unit
Power Dissipation per Dice	PD	114	mW
Derating Liner from 25°C per Dice	--	0.4	mA/°C
Continuous Forward Current Per Dice	IF	30	mA
Peak Current Per Dice (duty cycle 1/10, 1KHz)	IFP	100	mA
Reverse Voltage Per Dice	VR	5	V
Electrostatic Discharge (HBM)	ESD	1500	V
Operating Temperature	Topr	-40~+105	°C
Storage Temperature	Tstg	-40~+105	°C

**Electrical and Optical Characteristics at Ta=25 °C**

Parameter	Symbol	Min.	Typ.	Max.	Unit	Condition
Forward Voltage Per Segment	VF	--	3.2	3.8	V	IF=20mA
Luminous Intensity Per Segment	Iv	--	70	--	mcd	IF=10mA
Chromaticity Coordinates	X	--	0.27	--	nm	IF=10mA
	Y	--	0.25	--	nm	IF=10mA
Reverse Current	IR	--	--	50	μA	VR=5V
Luminous Intensity Matching Ratio	Iv-m	--	--	2:1	--	IF=10mA

**Luminous General Iv Bin Grade (IF = 10mA)**

A	B	C	D	E	F	G	H	J	K	L	M
0.155	0.249	0.399	0.640	1.025	1.641	2.627	4.204	6.727	10.764	17.224	27.559
0.248	0.398	0.639	1.024	1.640	2.626	4.203	6.726	10.763	17.223	27.558	44.095
N	P	Q	R	S	T	U	V	W	X	Y	1
44.096	70.555	112.889	180.623	288.997	462.397	739.836	1183.738	1893.982	3030.372	4848.597	7757.756
70.554	112.888	180.622	288.996	462.396	739.835	1183.737	1893.981	3030.371	4848.596	7757.755	12412.409
2	3	4	5	6	7	8	9				
12412.410	19859.858	31775.773	50841.238	81345.982	130153.573	208245.718	333193.149				
19859.857	31775.772	50841.237	81345.981	130153.572	208245.717	333193.148	533109.039				

*Color Rank Limits (IF = 10mA) – White Segments*

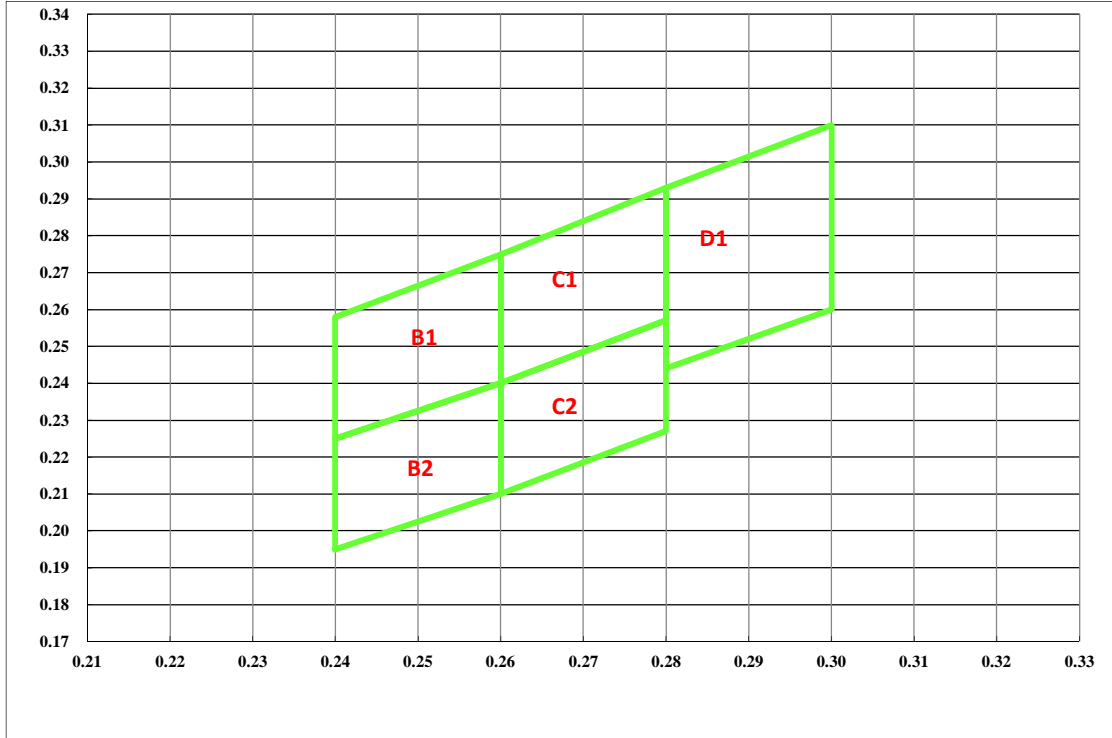

B1				
X	0.240	0.240	0.260	0.260
Y	0.225	0.258	0.275	0.240

B2				
X	0.240	0.240	0.260	0.260
Y	0.195	0.225	0.240	0.210

C1				
X	0.260	0.260	0.280	0.280
Y	0.240	0.275	0.293	0.257

C2				
X	0.260	0.260	0.280	0.280
Y	0.210	0.240	0.257	0.227

D1				
X	0.280	0.280	0.300	0.300
Y	0.244	0.293	0.310	0.260

***All Light-On Segments Feature & Pad Position***

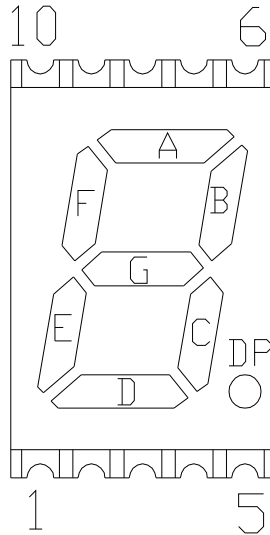

***Internal Circuit Diagram***

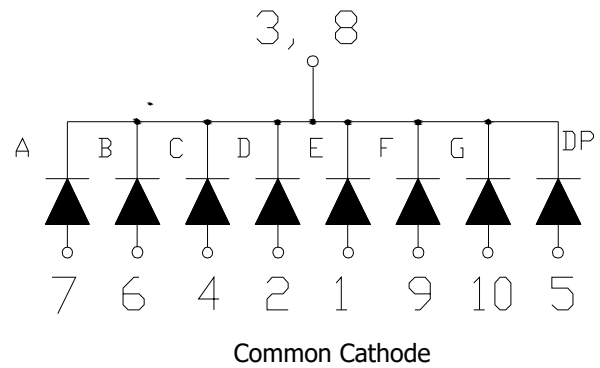
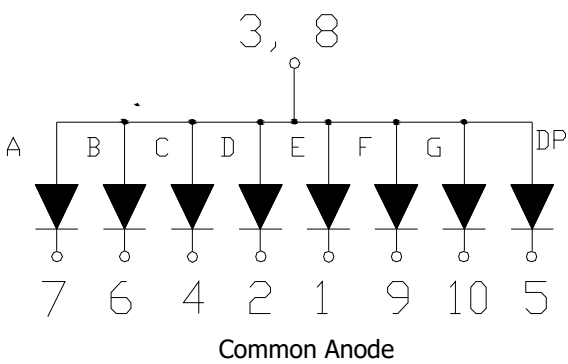

### Typical Electrical / Optical Characteristic Curves

- (Ta = 25°C Unless Otherwise Noted)

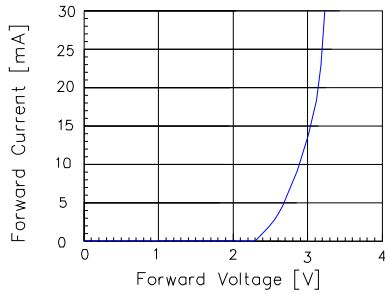

Fig 1. Forward Current vs. Forward Voltage

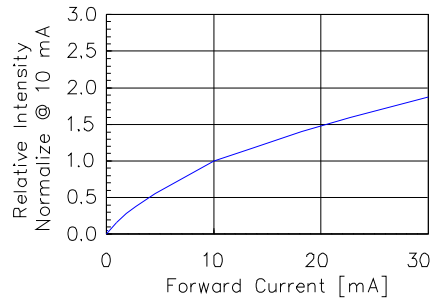

Fig 2. Relative Intensity vs. Forward Current

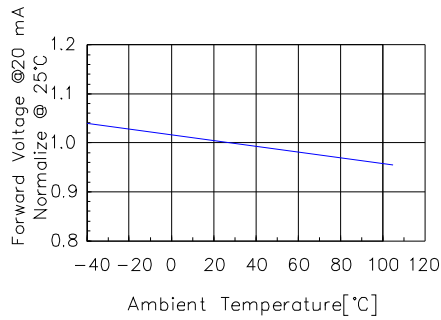

Fig 3. Forward Voltage vs. Temperature

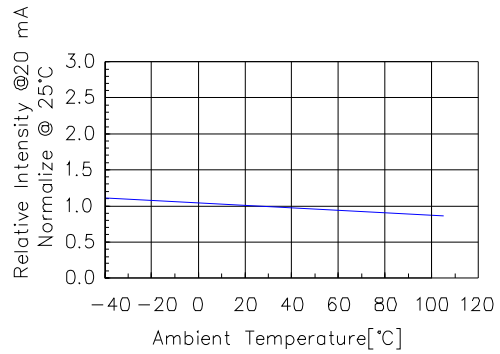

Fig 4. Relative Intensity vs. Temperature

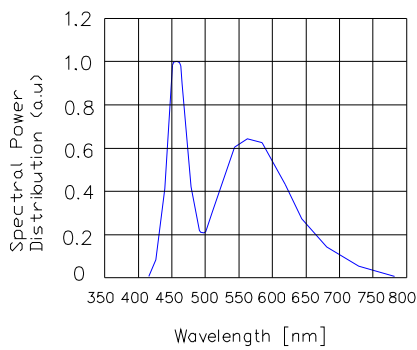

Fig 5. Spectral Power Distribution vs. Wavelength

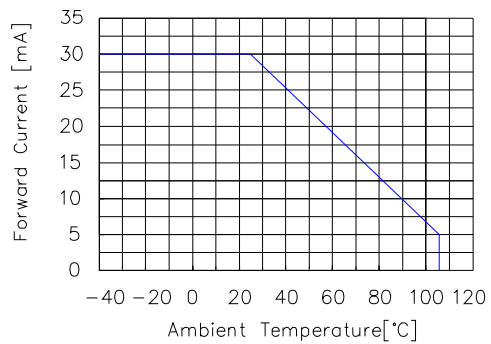
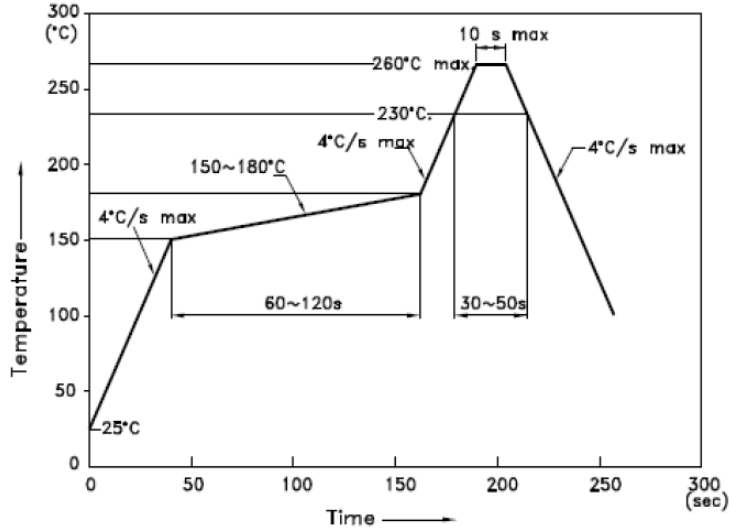

Fig 6. Forward current vs. Temperature

### SMT Reflow Soldering Instructions



**NOTES:**

1. We recommend the reflow temperature 245°C(+/-5°C). The maximum soldering temperature should be limited to 260°C.
2. Don't cause stress to the epoxy resin while it is exposed to high temperature.
3. Number of reflow process shall be 2 times or less.

### Soldering Pad Size

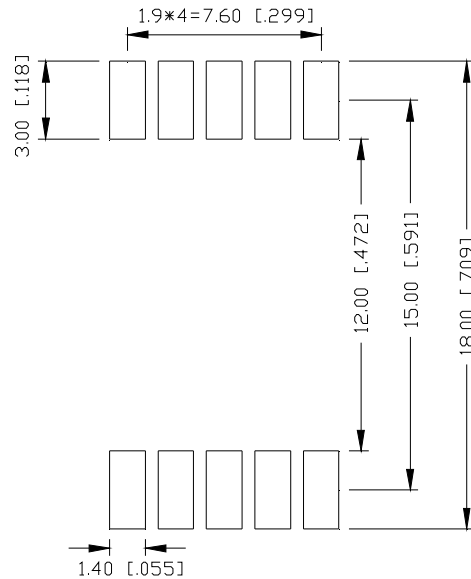

### Reel Specifications

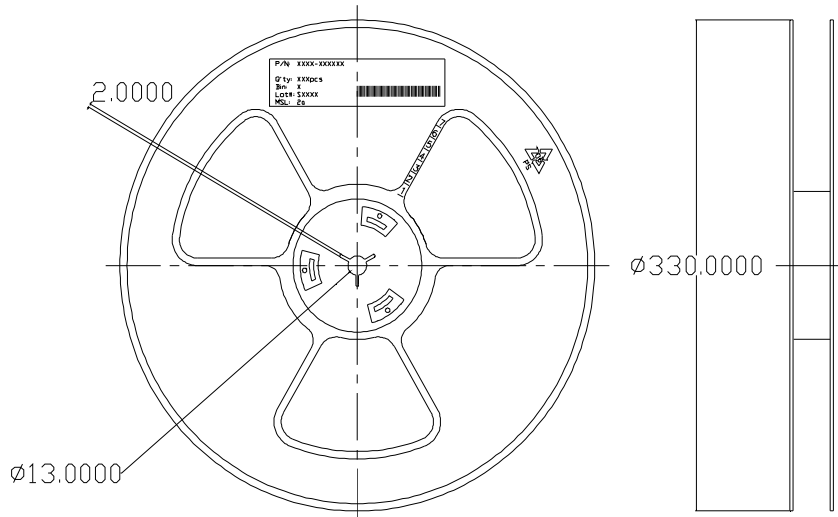

### Package and Label Specifications

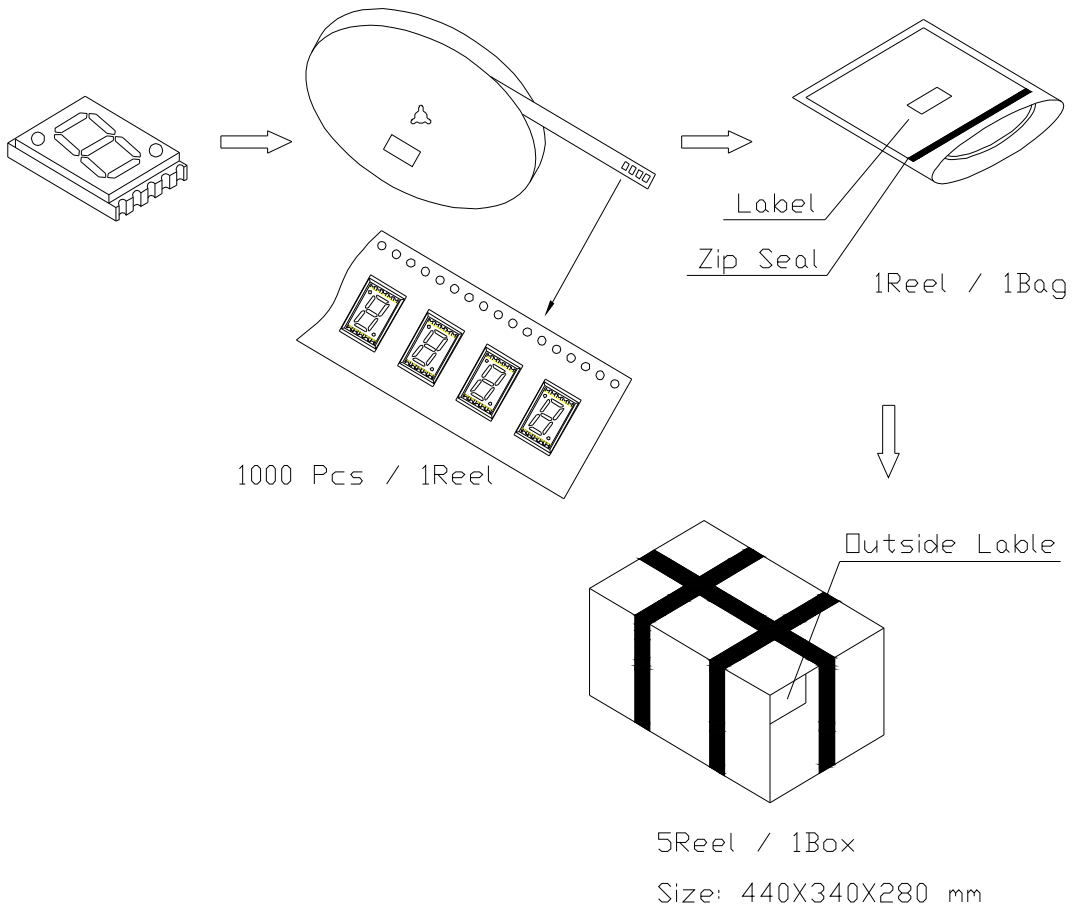

<b>Revision Record</b>			
<b>Rev.</b>	<b>Comments</b>	<b>Page</b>	<b>Date</b>
0	Released Spec	--	8/2/2023